

# MICROSAR FlexRay

## Embedded Software Modules for FlexRay Communication

FlexRay is a scalable, flexible and deterministic high-speed communication system that addresses the growing number of safety-related requirements in the automobile. Vector is offering MICROSAR FR to provide optimal support in developing your FlexRay systems.

### Properties and Advantages

The Basic Software Modules of MICROSAR FR are intended for production use. Together with the other products, MICROSAR CAL, MICROSAR COM and MICROSAR EXT, they form a complete FlexRay stack. Each of these MICROSAR products contains several Basic Software Modules, which you can integrate - either individually or as a full package - into your FlexRay stack.

All MICROSAR Basic Software Modules conform to AUTOSAR Release 3.0. The FlexRay-specific modules also support other functions such as:

- > Self-diagnostics of the FlexRay bus
- > Sending/receiving in Interrupt mode
- > Measuring and calibrating via XCP-on-FlexRay

When they were implemented, special emphasis was placed on efficient memory utilization as well as short execution times, so they are an ideal foundation for your AUTOSAR FlexRay stack. The time of configuration of all MICROSAR Basic Software Modules is user selectable, because the Vector Basic Software Modules are pre-compile, link-time and post-build capable (in accordance with AUTOSAR Configuration Conformance Classes CCC1 through CCC3).

You can combine the MICROSAR FR Basic Software Modules with the remaining MICROSAR Basic Software Modules of the seamless Vector AUTOSAR solution. This will provide a reliable foundation for your ECU-specific software, so that you can focus on developing your application.

### Application Areas

MICROSAR FR contains all Basic Software Modules that a FlexRay stack needs for basic FlexRay communication. You can also use this stack to measure and calibrate AUTOSAR ECUs with XCP-on-FlexRay.

### Operating System

The FlexRay Basic Software Modules may be used without any operating system at all, but it makes sense to use a conventional OSEK-OS (e.g. Vector osCAN) or AUTOSAR OS. Vector MICROSAR OS is ideally suited for FlexRay applications.

### Functions

#### MICROSAR FR

- > FRIF - The FlexRay Interface module has a number of access functions that convert PDUs of higher communication layers into FlexRay frames, asynchronous to the global FlexRay time.
- > FRNM - The FlexRay Network Management module will execute a coordinated ramp-down of the FlexRay cluster.
- > FRSM - The FlexRay State Manager controls and monitors synchronization of the nodes on the FlexRay cluster.

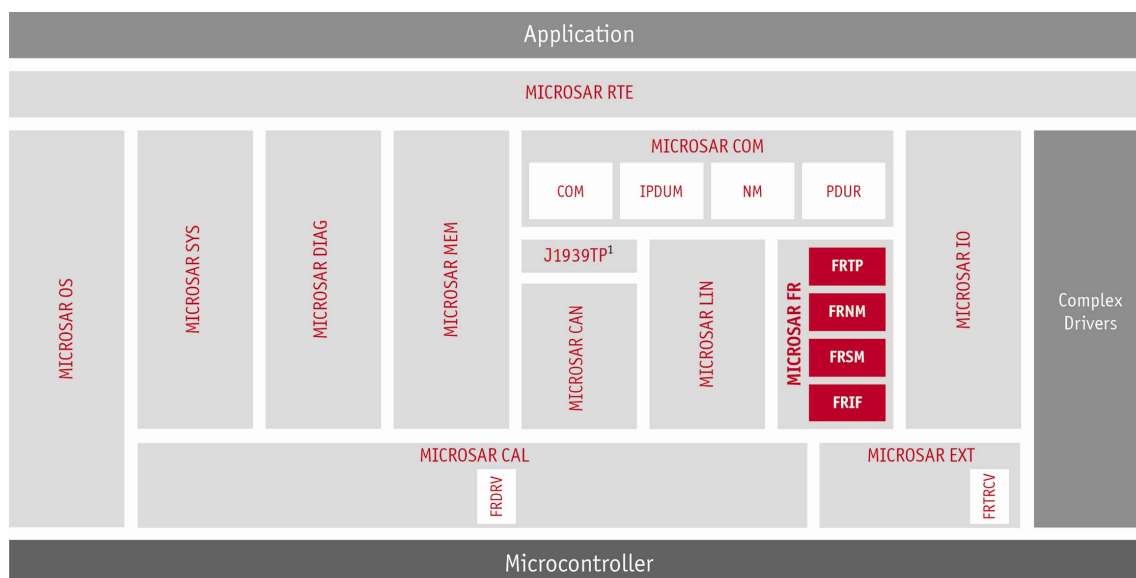

**MICROSAR FlexRay modules**

<sup>1</sup> Available extensions for AUTOSAR 3.0

**Training Courses**

We offer various training courses and workshops for AUTOSAR and FlexRay in our classrooms or at your business site. For further information on individual training events and dates on the Internet go to: [www.vector-academy.com](http://www.vector-academy.com).

**Contact and Availability**

Vector offers you FlexRay communication modules for hardware platforms with various integrated or external FlexRay communication controllers. You can obtain additional information at [www.flexray-solutions.com](http://www.flexray-solutions.com) or by inquiry E-mail: [embedded@vector-informatik.com](mailto:embedded@vector-informatik.com) Telephone: +49 711 80670 400

- > FRTP/FRISOTP - The FlexRay Transport Protocol module handles the transfer of larger data packets. In anticipation of the AUTOSAR release 4.0, you can replace the FRTP by a FRISOTP in the FlexRay stack of the AUTOSAR release 3.0 if the usage of the FRISOTP according to ISO 10681 is required.

To fully integrate a FlexRay stack into your application you need other modules from the following MICROSAR products: MICROSAR DIAG (DCM, DEM), MICROSAR SYS (DET, ECUM, COMM), MICROSAR RTE.

**Other relevant MICROSAR Products**

- > MICROSAR CAL (FRDRV) - The controller-specific FlexRay driver provides the interface to the FlexRay controller to be used by the FlexRay interface FRIF.
- > MICROSAR COM - This product supports signal-based communication between different ECUs, as well as signal and PDU routing.
- > MICROSAR EXT (FRTRCV) - The Transceiver-Driver provides an interface for driving an external transceiver device.

**Configuration**

The MICROSAR FR modules are configured with the familiar configuration tool GENy (included in the DaVinci Configurator Pro delivery) and the AUTOSAR ECU Configuration Description, which is based on the AUTOSAR System Description. Network descriptions

in FIBEX format are also supported. The network description is created using the DaVinci Network Designer from Vector.

**Scope of Delivery**

- > DaVinci Configurator Base as a Generic ECU Configuration Editor (GCE) as well as a command line-based generator
- > Libraries, C header files, optionally with source code
- > BSW Module Description, makefiles and sample programs
- > Documentation/operating instructions/Readme file

**License**

Vector offers flexible licensing customized to your individual requirements.

**Optional Services**

- > Consultation in system design
- > Integrating the Basic Software into existing ECUs
- > Extending standard modules according to your needs
- > Developing customer-specific AUTOSAR Software Components (SWC)
- > Hotline, special workshops and training courses on the topic of embedded software and AUTOSAR

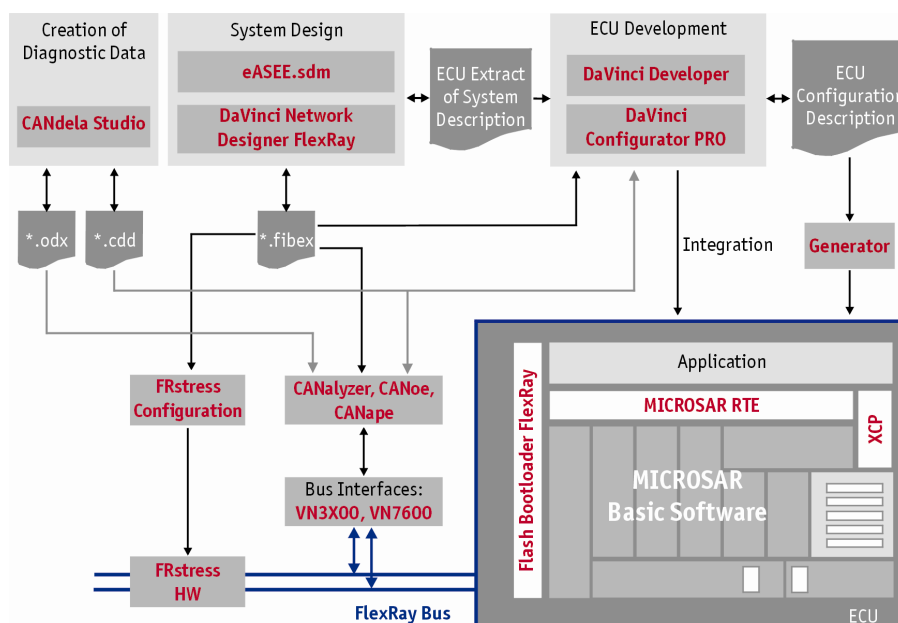

**Vector offers a comprehensive product lineup for your FlexRay projects**