

# IOcab 8444opto

The new IO interface cable for acquiring analog and digital signals.

A powerful user-friendly hardware interface is necessary to acquire analog and digital signals in automotive networks. In its well known compact CANcab package the IOcab 8444opto is the ideal product for use with notebooks or desktop computers.

## Features and Advantages

With its powerful microcontroller and advanced hardware design the IOcab 8444opto is well suited for a large number of measurement and test applications.

An overview of product characteristics:

- > Up to 8 digital inputs (4 Schmitt triggers)
- > Up to 4 digital outputs (high-side and/or low-side)
- > Up to 4 analog inputs
- > Up to 4 analog outputs
- > One analog comparator
- > One PWM output or one CAPTURE input
- > Opto decoupled

During the development of the IOcab, special emphasis was placed on precise time synchronization and on low latency times.

## Functions

IOcab 8444opto functional features include:

- > Measurement of digital and analog values
- > Sending of digital signals\*
- > Output of analog signals\*
- > Time-correlated acquisition of signals and signal changes
- > Precise time stamp
- > Simultaneous and also mixed operation of multiple IO-/CAN-/LINcabs
- > Firmware update possible at customer site

## Application Areas

With the IOcab 8444opto Vector offers the user an extension of the CANcab product family. In connection with a CANoe or CANape the IOcab 8444opto is especially well suited for systems in which network messages are generated or acquired together with analog and digital signals.

The IOcab 8444opto covers all application areas, in which CANcardXLe or CANcardXL is also used:

- > Automobile technology
- > Commercial vehicle technology
- > Automation technology
- > Air and space technology
- > Marine technology



The XL-Driver-Library supports all IOcab functions, thus allowing the user to create his own applications. Due to the standardized XCP interface functions of already existing applications can be used without adaptations.

**Included with Delivery**

- > IOcab 8444opto
- > Documentation

A CANcardXLe or CANcardXL is needed to operate IOcab 8444opto. It is not included with delivery.

**Technical Data**

Area of application	Mobile, stationary
Digital inputs	Up to 8 inputs; -36 V..36 V; 4 Schmitt trigger inputs; trigger function
Digital outputs*	Up to 4 outputs; -36 V..36 V; 200 mA; high-side and/ or low-side; readback capable
PWM	1 output; CMOS level 1. range: 2.4 kHz..100 kHz; 2. range: min. pulse/pause period: 100 µs; max. pulse/pause period: 25.5 ms;
Capture input	1 input; min. pulse/pause period: 5 µs; max. pulse/pause period: 50 ms; ±1 % accuracy
Analog inputs	Up to 4 inputs; 0 V..32 V; ±1.5 % accuracy 2 measurement ranges; 10 bit resolution
Analog outputs*	Up to 4 outputs; 0 V .. 4.096 V; 12 bit resolution
Analog comparator	1 comparator; 0 V..32 V; 12 bit resolution of trigger threshold
Opto decoupling	Each digital output separately; Data bus to CANcardXLe or CANcardXL
Plug connector	DSUB15; Low density
PC interface	CANcardXLe, CANcardXL
Temperature range	Operation: -20 V..+55 °C; Storage: -40 ..+85 °C
Installation	Plug & Play
Current consumption	Typ. 180 mA; max. 200 mA
Time stamp accuracy	2 µs
Sample rate	1 kHz; 3 kHz via CAN Driver Library

\* Maximum switching frequency 20Hz.  
See manual for further details.

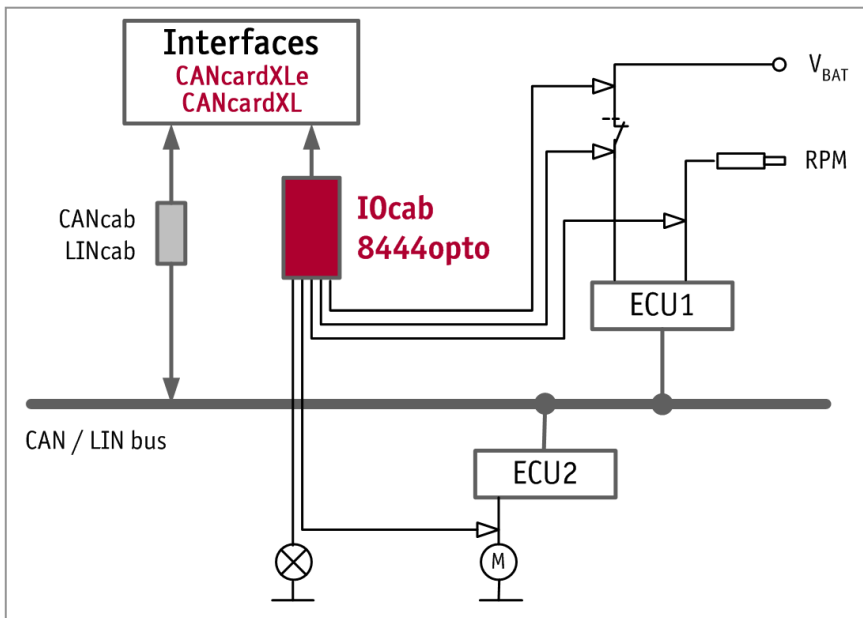

**Use Cases of the IOcab**